

B

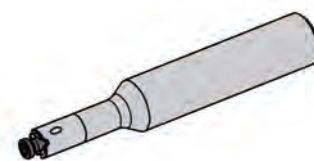
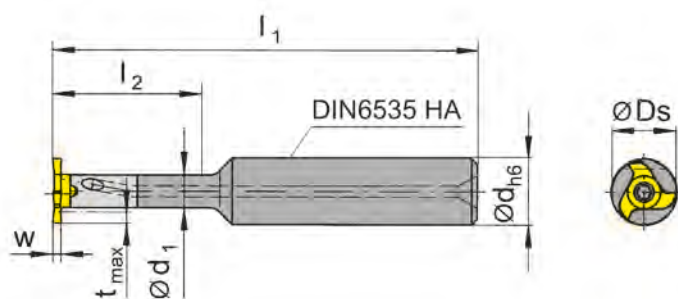
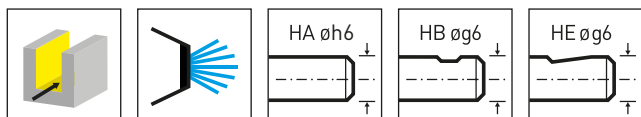

型式 Part number	d	l ₁	l ₂	d ₁	形状 Form	HWS
M306.0012.01A	12	80	21	6	A	306060R • 306060L
M306.0012.02A	12	90	30	6	A	306060R • 306060L
M306.0012.03A	12	100	42	6	A	306060R • 306060L
M306.0012.01B	12	80	21	6	B	306060R • 306060L
M306.0012.02B	12	90	30	6	B	306060R • 306060L
M306.0012.03B	12	100	42	6	B	306060R • 306060L
M306.0012.01E	12	80	21	6	E	306060R • 306060L
M306.0012.02E	12	90	30	6	E	306060R • 306060L
M306.0012.03E	12	100	42	6	E	306060R • 306060L

w, Ds, tmaxの寸法はインサートページをご参照ください。
w, Ds, tmax see inserts

予備部品
Spare Parts

ミーリングシャンク Milling shank	ねじ Clamping Screw	トルクスレンチ TORX PLUS® Wrench
M306...	2.6.5T8EP	T8PL



図 = 右勝手バージョン
Picture = right hand cutting version

超硬材種
Carbide grades
▲ 在庫品
on stock
△ 4週間
4 weeks

型式 Part number	Ds	E	s	t_{max}	Z	HIS	AS45
606.6060.05	11.7	1.9	3.75	2	6	306060R	▲
							P ●
							M ●
							K ●
							N ○
							S ●
							H -

B

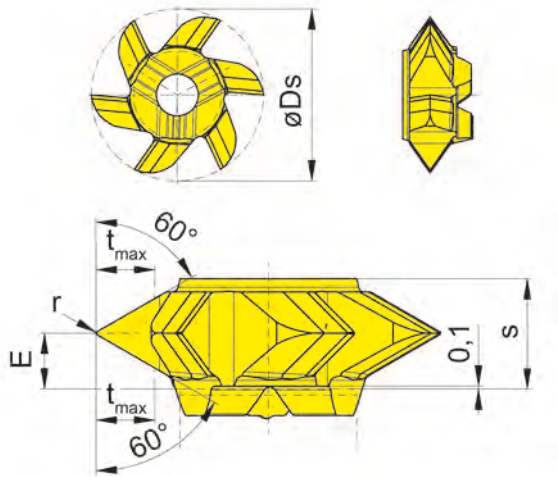
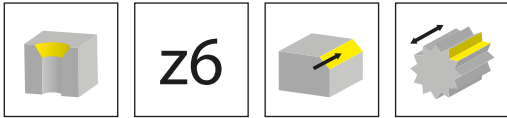
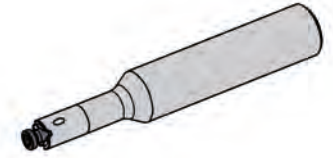
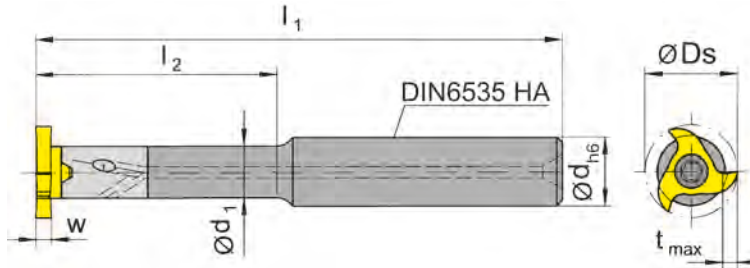
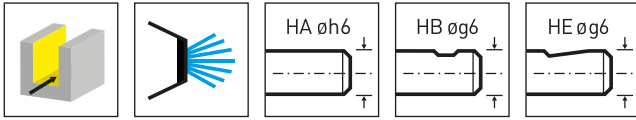

型式 Part number	d	l ₁	l ₂	d ₁	形状 Form	HWS
M313.0012.01A	12	100	-	-	A	313113R • 313113L
M313.0012.02A	12	130	-	-	A	313113R • 313113L
M313.0016.01A	16	100	42	12	A	313113R • 313113L
M313.0016.02A	16	130	60	12	A	313113R • 313113L
M313.0016.03A	16	160	85	12	A	313113R • 313113L
M313.0012.01B	12	100	-	-	B	313113R • 313113L
M313.0012.02B	12	130	-	-	B	313113R • 313113L
M313.0016.01B	16	100	42	12	B	313113R • 313113L
M313.0016.02B	16	130	60	12	B	313113R • 313113L
M313.0016.03B	16	160	85	12	B	313113R • 313113L
M313.0012.01E	12	100	-	-	E	313113R • 313113L
M313.0012.02E	12	130	-	-	E	313113R • 313113L
M313.0016.01E	16	100	42	12	E	313113R • 313113L
M313.0016.02E	16	130	60	12	E	313113R • 313113L
M313.0016.03E	16	160	85	12	E	313113R • 313113L

w, Ds, tmaxの寸法はインサートページをご参照ください。
w, Ds, tmax see inserts

予備部品
Spare Parts

ミーリングシャンク Milling shank	ねじ Clamping Screw	トルクスレンチ TORX PLUS® Wrench
M313...	5.14T20P	T20PQ

B



図 = 右勝手バージョン
Picture = right hand cutting version

超硬材種
Carbide grades

▲ 在庫品
on stock

△ 4週間
4 weeks

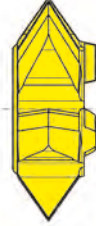
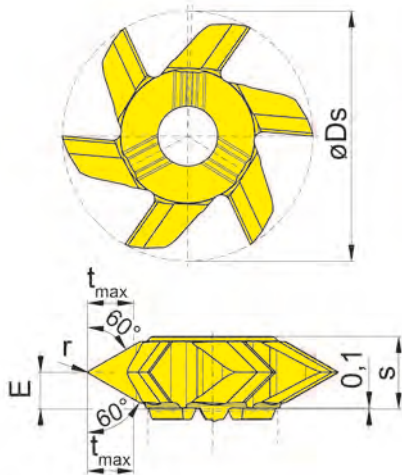
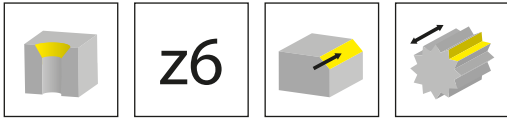
型式 Part number	Ds	E	s	r	t _{max}	Z	HIS	AS45
613.6060.05	21.7	3.2	6.3	0.05	4	6	313113R	▲
								P ●
								M ●
								K ●
								N ○
								S ●
								H -