



新ツールホルダーシステム 224

逃げ面とすくい面から
確実なクーラント供給

NEW TOOLHOLDER FOR THE SYSTEM 224

FLANK AND RAKE FACE COOLING FOR
HIGHER PERFORMANCE



特長：

THE DIFFERENCE: MORE POSSIBILITIES

- **確実に刃先にクーラントを供給できる
ため安定した加工が可能**

Targeted coolant supply for high
cutting performance

- **多様なクーラント接続に対応**

Universal coolant connection to the
toolholder

- **優れたホルダー素材で工具長寿命化に
貢献**

High strength material for a
long tool life

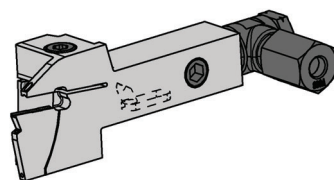
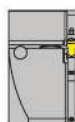
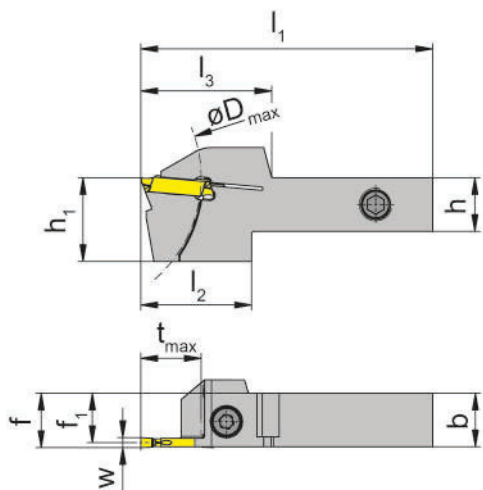
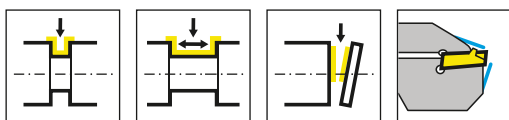

型式 Part number	h	b	l ₁	l ₂	l ₃	h ₁	f ₁	f	t _{max}	D _{max}	w	HWS
RH224.1616.14.0A.02.IK	16	16	83	29	35	25	15,2	f ₁ +w/2	14	80	2	224018
RH224.2020.14.0A.02.IK	20	20	95	29	35	25	19,2	f ₁ +w/2	14	80	2	224018
RH224.2525.14.0A.02.IK	25	25	110	29	35	30	24,2	f ₁ +w/2	14	80	2	224018
RH224.1616.14.0A.25.IK	16	16	83	29	35	25	14,95	f ₁ +w/2	14	80	2,5	224028
RH224.2020.14.0A.25.IK	20	20	95	29	35	25	18,95	f ₁ +w/2	14	80	2,5	224028
RH224.2525.14.0A.25.IK	25	25	110	29	35	30	23,95	f ₁ +w/2	14	80	2,5	224028
RH224.1616.14.0A.03.IK	16	16	83	29	35	25	14,75	f ₁ +w/2	14	80	3	224038
RH224.2020.14.0A.03.IK	20	20	95	29	35	25	18,75	f ₁ +w/2	14	80	3	224038
RH224.2525.14.0A.03.IK	25	25	110	29	35	30	23,75	f ₁ +w/2	14	80	3	224038
LH224.1616.14.0A.02.IK	16	16	83	29	35	25	15,2	f ₁ +w/2	14	80	2	224018
LH224.2020.14.0A.02.IK	20	20	95	29	35	25	19,2	f ₁ +w/2	14	80	2	224018
LH224.2525.14.0A.02.IK	25	25	110	29	35	30	24,2	f ₁ +w/2	14	80	2	224018
LH224.1616.14.0A.25.IK	16	16	83	29	35	25	14,95	f ₁ +w/2	14	80	2,5	224028
LH224.2020.14.0A.25.IK	20	20	95	29	35	25	18,95	f ₁ +w/2	14	80	2,5	224028
LH224.2525.14.0A.25.IK	25	25	110	29	35	30	23,95	f ₁ +w/2	14	80	2,5	224028
LH224.1616.14.0A.03.IK	16	16	83	29	35	25	14,75	f ₁ +w/2	14	80	3	224038
LH224.2020.14.0A.03.IK	20	20	95	29	35	25	18,75	f ₁ +w/2	14	80	3	224038
LH224.2525.14.0A.03.IK	25	25	110	29	35	30	23,75	f ₁ +w/2	14	80	3	224038

予備部品

Spare Parts

ツールホルダー Toolholder	給油部品 Coolant supply	クランプねじ Clamping Screw	トルクスレンチ TORX PLUS® Wrench
R/LH224...	004.00.16	6.23T25P	T25PQ

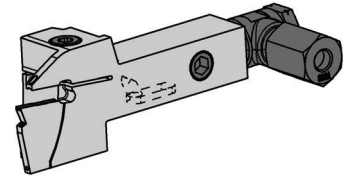
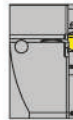
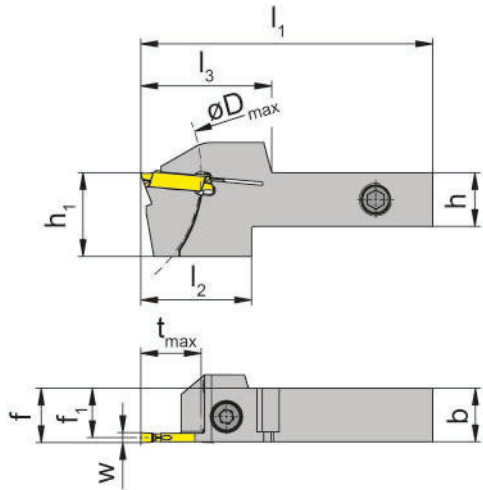
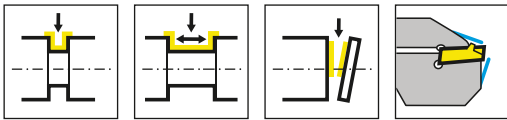

型式 Part number	h	b	l ₁	l ₂	l ₃	h ₁	f ₁	f	t _{max}	D _{max}	w	HWS
RH224.1616.14.0A.04.IK	16	16	83	29	35	25	14,3	f ₁ +w/2	14	80	4	224048
RH224.2020.14.0A.04.IK	20	20	95	29	35	25	18,3	f ₁ +w/2	14	80	4	224048
RH224.2525.14.0A.04.IK	25	25	110	29	35	30	23,3	f ₁ +w/2	14	80	4	224048
RH224.1616.14.0A.05.IK	16	16	83	29	35	25	13,95	f ₁ +w/2	14	80	5	224058
RH224.2020.14.0A.05.IK	20	20	95	29	35	25	17,95	f ₁ +w/2	14	80	5	224058
RH224.2525.14.0A.05.IK	25	25	110	29	35	30	22,95	f ₁ +w/2	14	80	5	224058
RH224.1616.14.0A.06.IK	16	16	83	29	35	25	13,6	f ₁ +w/2	14	80	6	224068
RH224.2020.14.0A.06.IK	20	20	95	29	35	25	17,6	f ₁ +w/2	14	80	6	224068
RH224.2525.14.0A.06.IK	25	25	110	29	35	30	22,6	f ₁ +w/2	14	80	6	224068
LH224.1616.14.0A.04.IK	16	16	83	29	35	25	14,3	f ₁ +w/2	14	80	4	224048
LH224.2020.14.0A.04.IK	20	20	95	29	35	25	18,3	f ₁ +w/2	14	80	4	224048
LH224.2525.14.0A.04.IK	25	25	110	29	35	30	23,3	f ₁ +w/2	14	80	4	224048
LH224.1616.14.0A.05.IK	16	16	83	29	35	25	13,95	f ₁ +w/2	14	80	5	224058
LH224.2020.14.0A.05.IK	20	20	95	29	35	25	17,95	f ₁ +w/2	14	80	5	224058
LH224.2525.14.0A.05.IK	25	25	110	29	35	30	22,95	f ₁ +w/2	14	80	5	224058
LH224.1616.14.0A.06.IK	16	16	83	29	35	25	13,6	f ₁ +w/2	14	80	6	224068
LH224.2020.14.0A.06.IK	20	20	95	29	35	25	17,6	f ₁ +w/2	14	80	6	224068
LH224.2525.14.0A.06.IK	25	25	110	29	35	30	22,6	f ₁ +w/2	14	80	6	224068

予備部品

Spare Parts

ツールホルダー Toolholder	給油部品 Coolant supply	クランプねじ Clamping Screw	トルクスレンチ TORX PLUS® Wrench
R/LH224...	004.00.16	6.23T25P	T25PQ

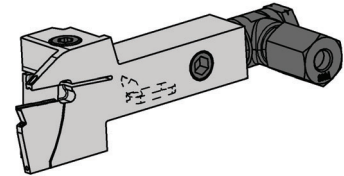
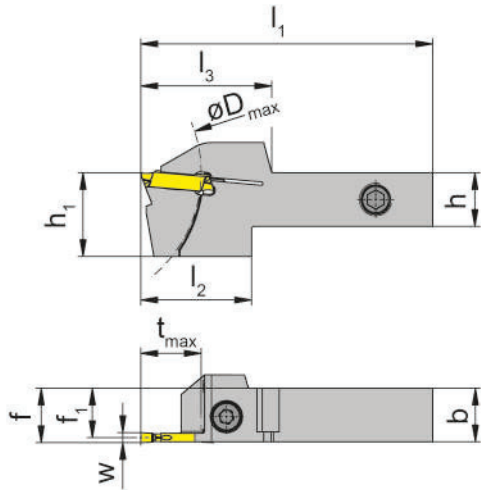
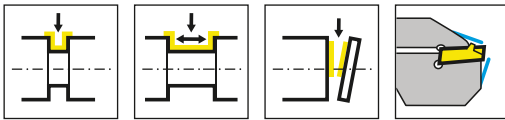

型式 Part number	h	b	l ₁	l ₂	l ₃	h ₁	f ₁	f	t _{max}	D _{max}	w	HWS
RH224.1616.18.0A.02.IK	16	16	87	33	39	25	15,2	f ₁ +w/2	18	80	2	224018
RH224.2020.18.0A.02.IK	20	20	99	33	39	25	19,2	f ₁ +w/2	18	80	2	224018
RH224.2525.18.0A.02.IK	25	25	114	33	39	30	24,2	f ₁ +w/2	18	80	2	224018
RH224.1616.18.0A.25.IK	16	16	87	33	39	25	14,95	f ₁ +w/2	18	80	2,5	224028
RH224.2020.18.0A.25.IK	20	20	97	33	39	25	18,95	f ₁ +w/2	18	80	2,5	224028
RH224.2525.18.0A.25.IK	25	25	114	33	39	30	23,95	f ₁ +w/2	18	80	2,5	224028
RH224.1616.18.0A.03.IK	16	16	87	33	39	25	14,75	f ₁ +w/2	18	80	3	224038
RH224.2020.18.0A.03.IK	20	20	99	33	39	25	18,75	f ₁ +w/2	18	80	3	224038
RH224.2525.18.0A.03.IK	25	25	114	33	39	30	23,75	f ₁ +w/2	18	80	3	224038
LH224.1616.18.0A.02.IK	16	16	87	33	39	25	15,2	f ₁ +w/2	18	80	2	224018
LH224.2020.18.0A.02.IK	20	20	99	33	39	25	19,2	f ₁ +w/2	18	80	2	224018
LH224.2525.18.0A.02.IK	25	25	114	33	39	30	24,2	f ₁ +w/2	18	80	2	224018
LH224.1616.18.0A.25.IK	16	16	87	33	39	25	14,95	f ₁ +w/2	18	80	2,5	224028
LH224.2020.18.0A.25.IK	20	20	97	33	39	25	18,95	f ₁ +w/2	18	80	2,5	224028
LH224.2525.18.0A.25.IK	25	25	114	33	39	30	23,95	f ₁ +w/2	18	80	2,5	224028
LH224.1616.18.0A.03.IK	16	16	87	33	39	25	14,75	f ₁ +w/2	18	80	3	224038
LH224.2020.18.0A.03.IK	20	20	99	33	39	25	18,75	f ₁ +w/2	18	80	3	224038
LH224.2525.18.0A.03.IK	25	25	114	33	39	30	23,75	f ₁ +w/2	18	80	3	224038

予備部品

Spare Parts

ツールホルダー Toolholder	給油部品 Coolant supply	クランプねじ Clamping Screw	トルクスレンチ TORX PLUS® Wrench
R/LH224...	004.00.16	6.23T25P	T25PQ

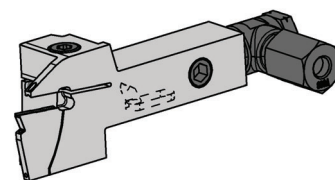
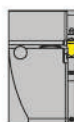
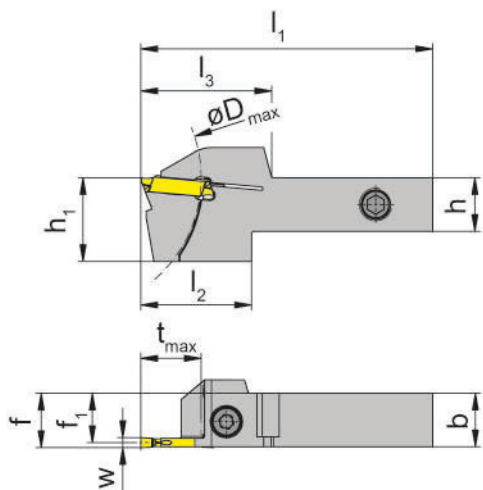
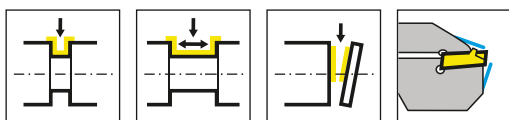

型式 Part number	h	b	l ₁	l ₂	l ₃	h ₁	f ₁	f	t _{max}	D _{max}	w	HWS
RH224.1616.18.0A.04.IK	16	16	87	33	39	25	14,3	f ₁ +w/2	18	80	4	224048
RH224.2020.18.0A.04.IK	20	20	99	33	39	25	18,3	f ₁ +w/2	18	80	4	224048
RH224.2525.18.0A.04.IK	25	25	114	33	39	30	23,3	f ₁ +w/2	18	80	4	224048
RH224.1616.18.0A.05.IK	16	16	87	33	39	25	13,95	f ₁ +w/2	18	80	5	224058
RH224.2020.18.0A.05.IK	20	20	99	33	39	25	17,95	f ₁ +w/2	18	80	5	224058
RH224.2525.18.0A.05.IK	25	25	114	33	39	30	22,95	f ₁ +w/2	18	80	5	224058
RH224.1616.18.0A.06.IK	16	16	87	33	39	25	13,6	f ₁ +w/2	18	80	6	224068
RH224.2020.18.0A.06.IK	20	20	99	33	39	25	17,6	f ₁ +w/2	18	80	6	224068
RH224.2525.18.0A.06.IK	25	25	114	33	39	30	22,6	f ₁ +w/2	18	80	6	224068
LH224.1616.18.0A.04.IK	16	16	87	33	39	25	14,3	f ₁ +w/2	18	80	4	224048
LH224.2020.18.0A.04.IK	20	20	99	33	39	25	18,3	f ₁ +w/2	18	80	4	224048
LH224.2525.18.0A.04.IK	25	25	114	33	39	30	23,3	f ₁ +w/2	18	80	4	224048
LH224.1616.18.0A.05.IK	16	16	87	33	39	25	13,95	f ₁ +w/2	18	80	5	224058
LH224.2020.18.0A.05.IK	20	20	99	33	39	25	17,95	f ₁ +w/2	18	80	5	224058
LH224.2525.18.0A.05.IK	25	25	114	33	39	30	22,95	f ₁ +w/2	18	80	5	224058
LH224.1616.18.0A.06.IK	16	16	87	33	39	25	13,6	f ₁ +w/2	18	80	6	224068
LH224.2020.18.0A.06.IK	20	20	99	33	39	25	17,6	f ₁ +w/2	18	80	6	224068
LH224.2525.18.0A.06.IK	25	25	114	33	39	30	22,6	f ₁ +w/2	18	80	6	224068

予備部品

Spare Parts

ツールホルダー Toolholder	給油部品 Coolant supply	クランプねじ Clamping Screw	トルクスレンチ TORX PLUS® Wrench
R/LH224...	004.00.16	6.23T25P	T25PQ



溝入れ加工のベストソリューションを
ご提案いたします。

FIND YOUR RIGHT
TOOLING SOLUTION NOW.

horn-group.com

輸入総代理店

—

株式会社IZUSHI

中部支店／刈谷テクニカルセンター

〒448-0807 愛知県刈谷市東刈谷町二丁目二番地 2

Tel 0566-62-8075

Fax 0566-62-8084

horn@ztec-izushi.co.jp

www.phhorn.jp

DEUTSCHLAND, STAMMSITZ

GERMANY, HEADQUARTERS

—

Hartmetall Werkzeugfabrik

Paul Horn GmbH

Horn-Straße 1

D-72072 Tübingen

Tel +49 7071 / 70040

Fax +49 7071 / 72893

info@de.horn-group.com

horn-group.com