

ph HORN ph



スーパーミニ／ミニ

ボーリング加工、端面加工用  
ラインアップ拡充

**SUPERMINI AND MINI**

EXTENSIONS FOR BORING AND AXIAL  
MACHINING



## 特長：

## THE DIFFERENCE: MORE POSSIBILITIES

- **ボーリング加工用の新インサートタイプを追加**

New insert types for boring

- **鋼の加工で高性能を発揮するコーティング**

High performance coating for common steels

- **端面加工用のラインアップ拡充**

Expanded possibilities for axial grooving

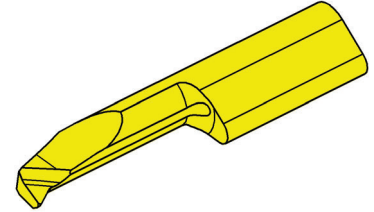
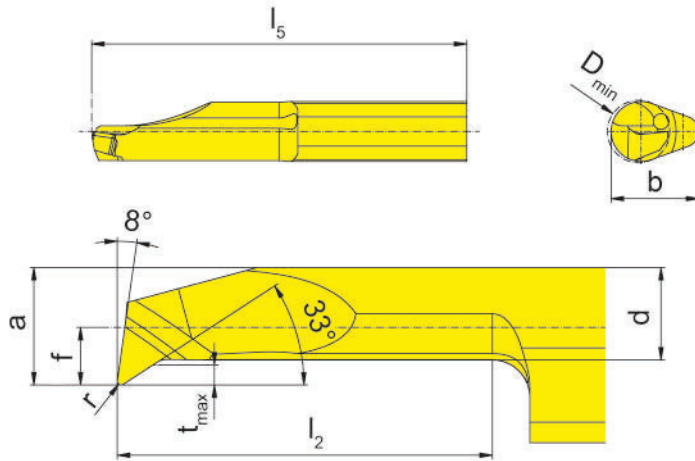
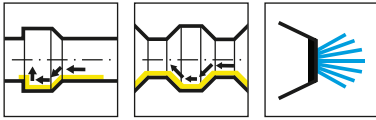

R = 右勝手バージョンを图示  
R = right hand version shown

L = 左勝手バージョン  
L = left hand version

▲ 在庫品  
on stock

超硬材種  
Carbide grades  
△ 4 週間  
4 weeks

型式 Part number	r	f	a	d	b	l <sub>2</sub>	l <sub>5</sub>	t <sub>max</sub>	D <sub>min</sub>	HIS	EG35
R105.3315.005.1.2	0,05	1,5	1,9	1,45	5,9	9	25	0,3	2	105123	▲
R105.3315.005.2.2	0,05	1,5	1,9	1,45	5,9	12	30	0,3	2	105123	▲
R105.3313.005.1.3	0,05	1,3	2,6	2	5,9	10	25	0,4	3	105123	▲
R105.3313.005.2.3	0,05	1,3	2,6	2	5,9	15	30	0,4	3	105123	▲
R105.3319.1.4	0,15	1,9	3,7	2,9	6,4	10	25	0,6	4	105124	▲
R105.3319.3.4	0,15	1,9	3,7	2,9	6,4	20	35	0,6	4	105124	▲
R105.3323.2.5	0,15	2,3	4,7	3,7	7	15	30	0,8	5	105125	▲
R105.3323.4.5	0,15	2,3	4,7	3,7	7	25	40	0,8	5	105125	▲
R105.3333.3.6	0,15	3,3	5,7	3,7	7	20	35	1,8	6	105125	▲
R105.3333.5.6	0,15	3,3	5,7	3,7	7	30	45	1,8	6	105125	▲
L105.3319.1.4	0,15	1,9	3,7	2,9	6,4	10	25	0,6	4	105124	△
L105.3319.3.4	0,15	1,9	3,7	2,9	6,4	20	35	0,6	4	105124	△
L105.3323.2.5	0,15	2,3	4,7	3,7	7	15	30	0,8	5	105125	△
L105.3323.4.5	0,15	2,3	4,7	3,7	7	25	40	0,8	5	105125	△
L105.3333.3.6	0,15	3,3	5,7	3,7	7	20	35	1,8	6	105125	△
L105.3333.5.6	0,15	3,3	5,7	3,7	7	30	45	1,8	6	105125	△

P	●
M	●
K	○
N	-
S	-
H	-

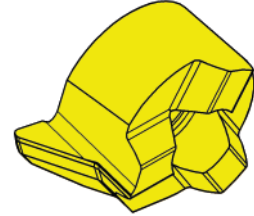
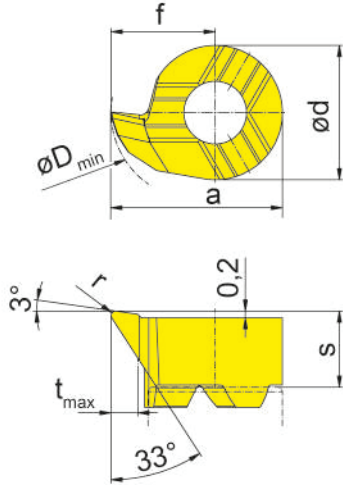
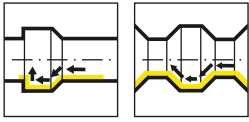

R = 右勝手バージョンを图示  
R = right hand version shown

L = 左勝手バージョン  
L = left hand version

▲ 在庫品  
on stock

超硬材種  
Carbide grades  
△ 4 週間  
4 weeks

型式 Part number	s	f	a	r	d	t <sub>max</sub>	D <sub>min</sub>	HIS	EG55
<b>R108.3348.01</b>	3,4	4,65	7,65	0,1	6	1,2	7,8	306060R	▲
<b>R108.3348.02</b>	3,4	4,65	7,65	0,2	6	1,2	7,8	306060R	▲
<b>R108.3348.04</b>	3,4	4,65	7,65	0,4	6	1,2	7,8	306060R	▲
<b>L108.3348.01</b>	3,4	4,65	7,65	0,1	6	1,2	7,8	306060L	△
<b>L108.3348.02</b>	3,4	4,65	7,65	0,2	6	1,2	7,8	306060L	△
<b>L108.3348.04</b>	3,4	4,65	7,65	0,4	6	1,2	7,8	306060L	△
									P ●
									M ○
									K ○
									N -
									S -
									H -

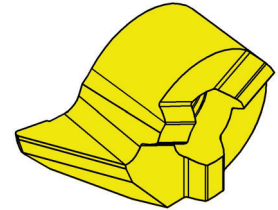
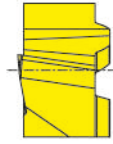
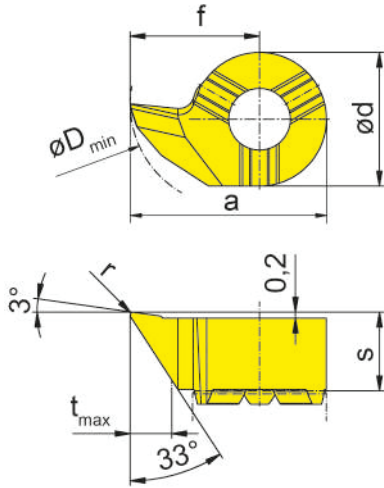
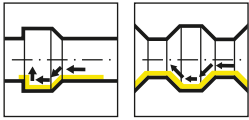

R = 右勝手バージョンを図示  
R = right hand version shown

L = 左勝手バージョン  
L = left hand version

▲ 在庫品  
on stock

超硬材種  
Carbide grades  
Δ 4 週間  
4 weeks

型式 Part number	s	f	a	r	d	t <sub>max</sub>	D <sub>min</sub>	HIS	EG55
R114.3387.02	5,3	8,7	13,2	0,2	9	2,8	13,8	311090R	▲
R114.3387.04	5,3	8,7	13,2	0,4	9	2,8	13,8	311090R	▲
L114.3387.02	5,3	8,7	13,2	0,2	9	2,8	13,8	311090L	Δ
L114.3387.04	5,3	8,7	13,2	0,4	9	2,8	13,8	311090L	Δ
									P ●
									M ○
									K ○
									N -
									S -
									H -

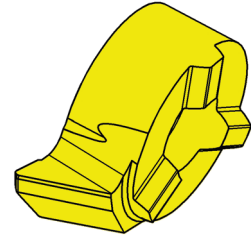
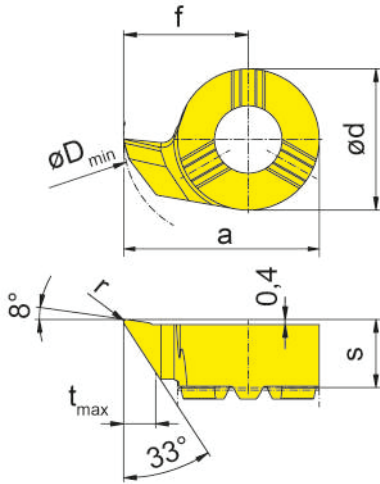
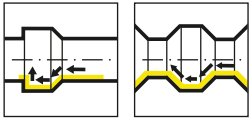

R = 右勝手バージョンを图示  
R = right hand version shown

L = 左勝手バージョン  
L = left hand version

▲ 在庫品  
on stock

超硬材種  
Carbide grades  
Δ 4 週間  
4 weeks

型式 Part number	s	f	a	r	d	t <sub>max</sub>	D <sub>min</sub>	HIS	EG55
<b>R116.3302.02</b>	5,3	9,7	15,2	0,2	11	2,5	15,5	116110R	▲
<b>R116.3302.04</b>	5,3	9,7	15,2	0,4	11	2,5	15,5	116110R	▲
<b>L116.3302.02</b>	5,3	9,7	15,2	0,2	11	2,5	15,5	116110L	Δ
<b>L116.3302.04</b>	5,3	9,7	15,2	0,4	11	2,5	15,5	116110L	Δ
									P ●
									M ○
									K ○
									N -
									S -
									H -

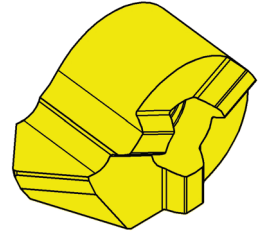
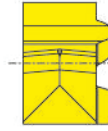
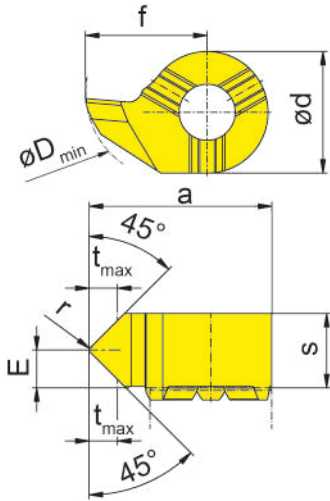
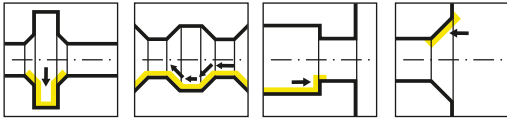

R = 右勝手バージョンを图示  
R = right hand version shown

L = 左勝手バージョン  
L = left hand version

超硬材種  
Carbide grades  
▲ 在庫品  
on stock  
Δ 4 週間  
4 weeks

型式 Part number	E	s	f	r	d	t <sub>max</sub>	D <sub>min</sub>	HIS	EG55
R114.4545.02	2,8	5,5	9	0,2	9	2,1	14	311090R	▲
L114.4545.02	2,8	5,5	9	0,2	9	2,1	14	311090L	Δ
									P ●
									M ○
									K ○
									N -
									S -
									H -



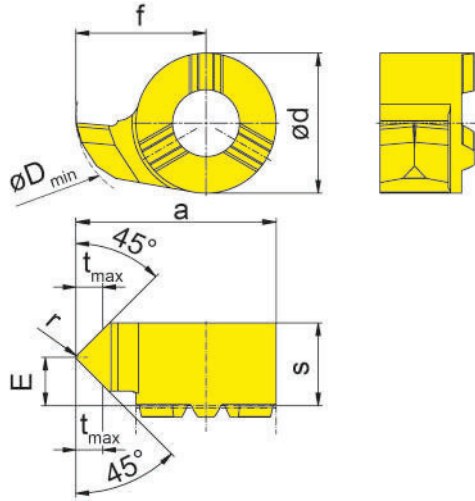
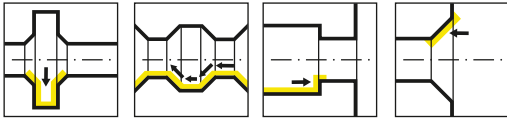

R = 右勝手バージョンを图示  
R = right hand version shown

L = 左勝手バージョン  
L = left hand version

▲ 在庫品  
on stock

超硬材種  
Carbide grades  
Δ 4 週間  
4 weeks

型式 Part number	E	s	f	a	r	d	t <sub>max</sub>	D <sub>min</sub>	HIS	EG55
<b>R116.4545.02</b>	3,8	6,5	10,2	15,7	0,2	11	2,1	16	116110R	▲
<b>L116.4545.02</b>	3,8	6,5	10,2	15,7	0,2	11	2,1	16	116110L	Δ
										P ●
										M ○
										K ○
										N -
										S -
										H -

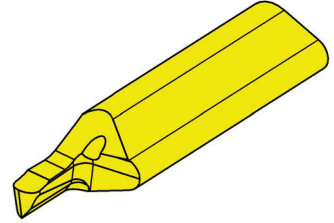
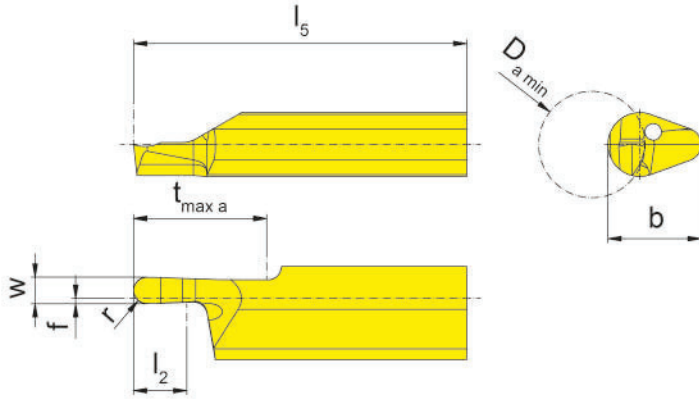
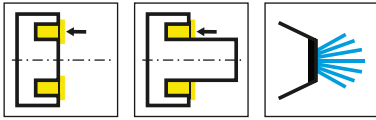

R = 右勝手バージョンを図示  
R = right hand version shown

L = 左勝手バージョン  
L = left hand version

▲ 在庫品  
on stock

超硬材種  
Carbide grades  
▲ 4 週間  
4 weeks

型式 Part number	w	r	f	b	l <sub>2</sub>	l <sub>5</sub>	t <sub>max a</sub>	D <sub>a min</sub>	HIS	EG35
R105.8V10.1.9	1	0,5	0,4	7	10	25	2	8	105125	▲
R105.8V16.1.9	1,6	0,8	0,4	7	10	25	3	8	105125	▲
R105.8V20.1.9	2	1	0,4	7	10	25	4	8	105125	▲
R105.8V25.1.9	2,5	1,25	0,4	7	10	25	5	8	105125	▲
R105.8V30.1.9	3	1,5	1	7	10	25	6	8	105125	▲
L105.8V10.1.9	1	0,5	0,4	7	10	25	2	8	105125	▲
L105.8V16.1.9	1,6	0,8	0,4	7	10	25	3	8	105125	▲
L105.8V20.1.9	2	1	0,4	7	10	25	4	8	105125	▲
L105.8V25.1.9	2,5	1,25	0,4	7	10	25	5	8	105125	▲
L105.8V30.1.9	3	1,5	1	7	10	25	6	8	105125	▲
										P ●
										M ●
										K ○
										N -
										S -
										H -

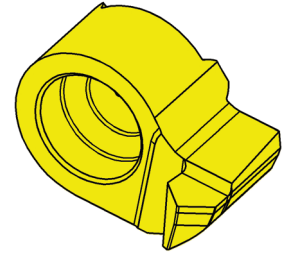
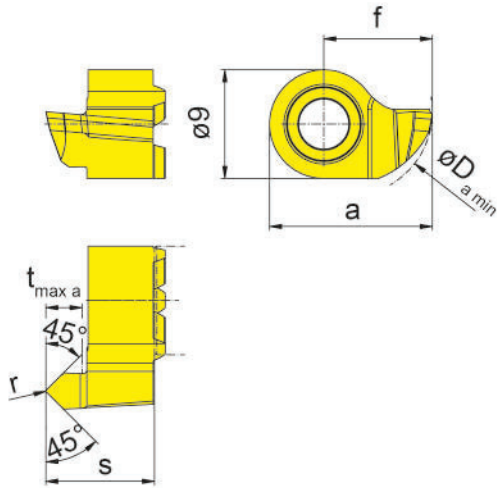
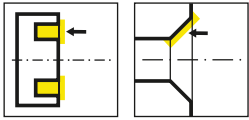

R = 右勝手バージョンを图示  
R = right hand version shown

L = 左勝手バージョン  
L = left hand version

▲ 在庫品  
on stock

超硬材種  
Carbide grades  
Δ 4 週間  
4 weeks

型式 Part number	s	f	a	r	t <sub>max a</sub>	D <sub>a min</sub>	HIS	EG55
<b>R114.4545.14</b>	9	9	13,5	0,1	3	14	311090R	▲
<b>L114.4545.14</b>	9	9	13,5	0,1	3	14	311090L	Δ
								P ●
								M ○
								K ○
								N -
								S -
								H -



溝入れ加工のベストソリューションを  
ご提案いたします。

FIND YOUR RIGHT  
TOOLING SOLUTION NOW.

[horn-group.com](http://horn-group.com)

輸入総代理店

—

**株式会社IZUSHI**

中部支店／刈谷テクニカルセンター

〒448-0807 愛知県刈谷市東刈谷町二丁目二番地 2

Tel 0566-62-8075

Fax 0566-62-8084

[horn@ztec-izushi.co.jp](mailto:horn@ztec-izushi.co.jp)

[www.phhorn.jp](http://www.phhorn.jp)

**DEUTSCHLAND, STAMMSITZ**

GERMANY, HEADQUARTERS

—

Hartmetall Werkzeugfabrik

Paul Horn GmbH

Horn-Straße 1

D-72072 Tübingen

Tel +49 7071 / 70040

Fax +49 7071 / 72893

[info@de.horn-group.com](mailto:info@de.horn-group.com)

[horn-group.com](http://horn-group.com)